



**REFORMER  
INSTALLATION AND USER GUIDE**



**REFORMER  
INSTALLATION AND USER GUIDE**

<b>1.</b>	<b>SAFETY INSTRUCTIONS</b>	<b>-----3</b>
<b>2.</b>	<b>GENERAL FEATURES</b>	<b>-----4</b>
	<b>2.1. Dimensions</b>	<b>4</b>
	<b>2.2. Accessories</b>	<b>4</b>
	<b>2.3. Components Diagram</b>	<b>5</b>
<b>3.</b>	<b>INSTALLATION</b>	<b>-----6</b>
	<b>3.1. Components List</b>	<b>6</b>
	<b>3.2. Instruments Required For Installation</b>	<b>8</b>
	<b>3.3. Installation Instructions</b>	<b>9</b>
	<b>3.4. Installation Instructions of Accessories</b>	<b>12</b>
	<b>3.4.1. Installation Instruction of the Handles</b>	<b>12</b>
	<b>3.4.2. Installation Instruction of the Jump Board</b>	<b>12</b>
<b>4.</b>	<b>MAINTENANCE INSTRUCTIONS</b>	<b>-----14</b>

## 1. SAFETY INSTRUCTIONS

If you do not use **ATRO REFORMER** properly; you can hurt yourself and you may cause injury or an accident. To reduce such risks, we recommend that you read the entire booklet before using the device.

Do not modify **ATRO REFORMER** and do not use other than those written. Otherwise, damage to the instrument will not be covered by the Warranty.

- Before starting the workout on **ATRO REFORMER** read all instructions which are in the user guide.
- Before starting the workout on **ATRO REFORMER** see a doctor and make a health check up.
- Use **ATRO REFORMER** with under the supervision of a professional trainer and only for the exercises the trainer has determined
- Adjust the system to your level before starting the training program and do not stand on the **ATRO REFORMER** when adjusting.
- If you feel any chest pain, fatigue, shortness of breath or fatigue in your muscles during exercises, stop exercising.
- Keep your body, clothes and hair away from moving parts of **ATRO REFORMER**.
- If any part of **ATRO REFORMER** has damaged or broken do not use the device.
- Do not attempt to repair the **ATRO REFORMER** on your own.
- Children should not use **ATRO REFORMER** without adult supervision.
- Make sure that the Foot Bar is tight, that the tap adjuster fits into the slots and does not move.
- After adjusting the gear bar, slide the safety lock and tighten the screws and ensure that the bar does not move upwards.
- Make sure the hooks of the foot belt are locked.
- Make sure the Push Through Bar shafts are fully seated in their slots. Do not leave the spring attached to it after use.
- When exercising with accessories attached to the upper springs in the tower, do not quickly release the accessories attached to the tensioned springs. If you release the spring quickly, it may cause the spring to strike and cause serious injury.
- Make sure the shoulder rests are set and the pins of the shoulder rests are tightened.
- Check all springs regularly and replace if springs are damaged.
- Make sure all pins are undamaged and tight.

## **2. GENERAL FEATURES**

- **ATRO REFORMER** will be delivered to you in a parcel. Installation is done by the user with the help of the installation video sent by **ATRO PILATES**.
- Standard and preferred working height for **ATRO REFORMER** is 200 cm.
- **ATRO REFORMER** has 4 adjustment stages and consists of 5 springs with different hardness. It is suitable for all sizes with adjustable ropes.

### **TABLE OF SPRINGS**

BLACK	VERY HARD
RED	HARD
GREEN	MEDIUM
BLUE	LIGHT
YELLOW	VERY LIGHT

#### **2.1. Dimensions**

METAL CASE : 69 cm (width) x 240 cm (length) x 35cm (height)  
(distance from the floor to the top of the case)

CARRIER MAIN BOARD : 62 cm (width) x 100 cm (length)

HEADREST : 17 cm (width) x 22 cm (length)

SHOULDER RESTS : 8 cm (width) x 8 cm (length) x 18 cm (length)

#### **2.2. Accessories**

- Box
- Handles
- Jump Board



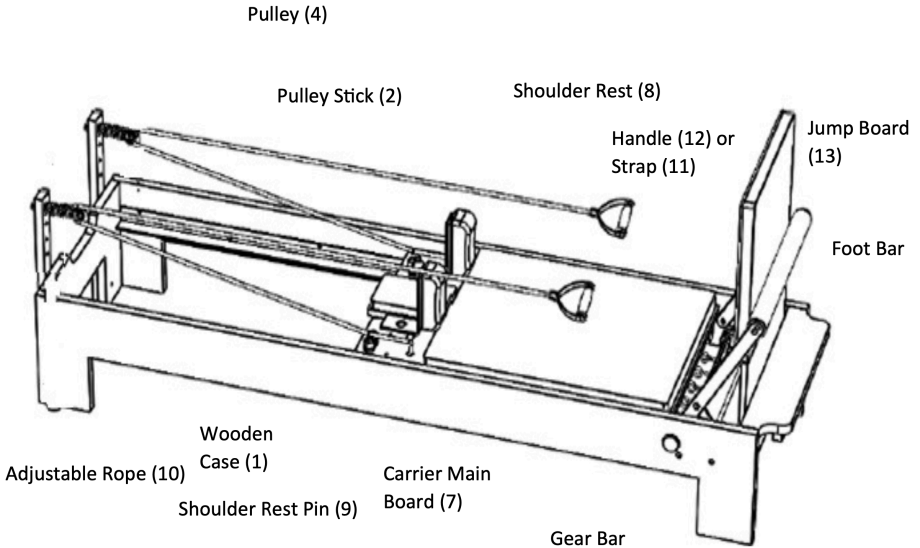

### 2.3. Components Diagram





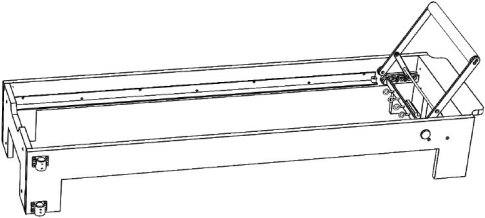
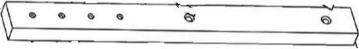

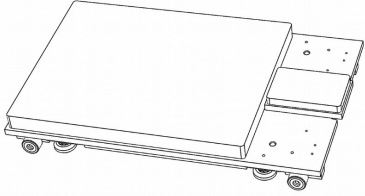
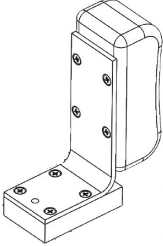

### 3. INSTALLATION

#### 3.1. Components List

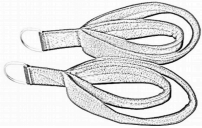
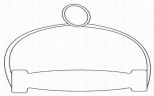
The following parts are the main parts of **ATRO REFORMER**:

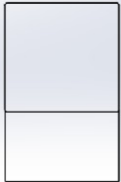
No	Component Name	Qntty	Picture
1	Wooden Case	1	
2	Pulley Stick	2	
3	Pulley Stick Screw	4	
4	Pulley	2	
5	Pulley Screw	2	
6	Pulley Lamella	2	

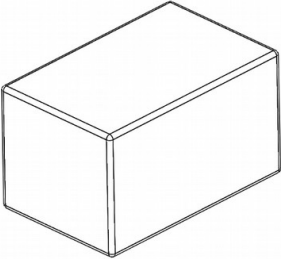
7	Carrier Main Board	1	
8	Shoulder Rest	2	
9	Shoulder Rest Pin	2	
10	Adjustable Rope	2	
11	Straps	2	
12	Handles	2	

13	Jump Board	1	
14	Jump Board Screw	2	
15	Box	1	
16	Foot Belt	1	

### **3.2. Instruments Required For Installation**

- Allan (4)
- Allan (5)

### 3.3. Installation Instructions

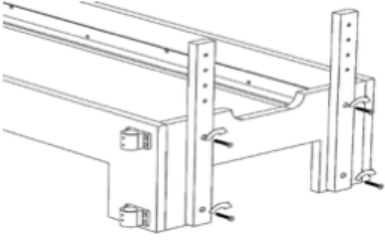
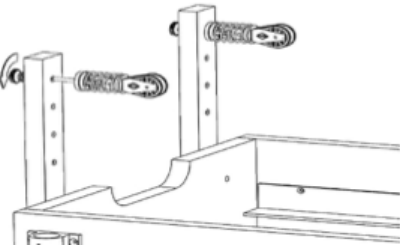
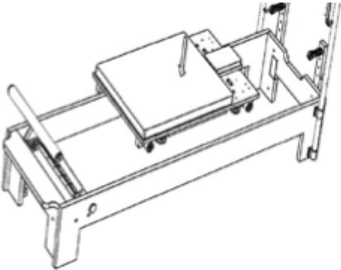
	<p>On the head side of the wooden case (1), there are 2 screw holes both on the right and on the left, for the installation of pulley sticks (2). Screw the pulley sticks with the help of the allen (5) as shown. Make sure that the pulley sticks do not move.</p>
	<p>Remove the pulley lamellas (6) and pulley screws (5) from the pulleys (4). There are 4 holes in each of the pulley sticks. The pulley pins should face out of the case as shown and the pulleys should be placed 90 degrees perpendicular to the case. Insert the lamellas that remove from the pulleys into the pin and tighten the screw by hand as shown. Make sure that the pulleys do not move.</p>
	<p>Place the carrier main board (7) that have the carriage wheel and spring assembly underneath on the wooden case. The head rest must be on the side of the pulleys. Make sure that the carrier wheel assembly is fully seated on the metal part inside the wooden case.</p>

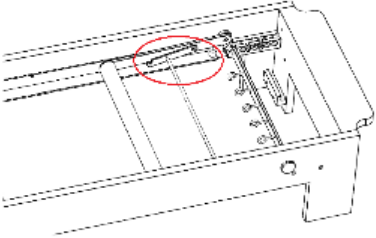
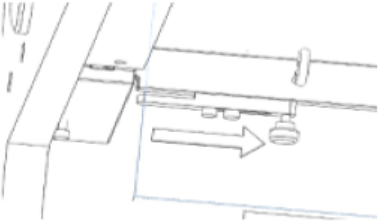
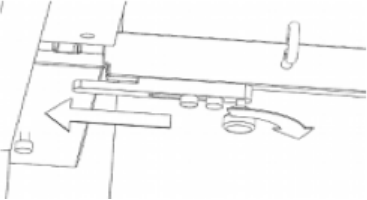
	<p>Move the positionable footbar on the underside of the wooden case as shown in the figure and close it into the case.</p>
	<p>After closing the footbar into the case as shown in the figure, close the tap adjuster in.</p>
	<p>Insert the length stoppers into the hole closest to the gear bar.</p>
	<p>Close the gear bar bolt as shown.</p>

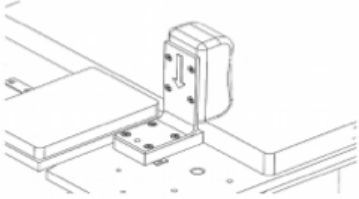
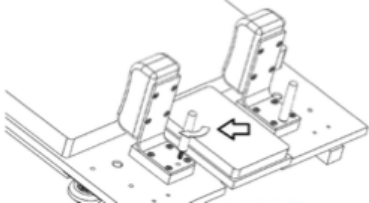
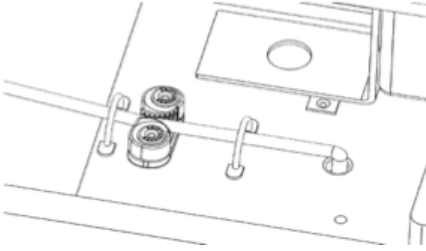
	<p>Fit the shoulder rests (9) into the pin slots on the side of the head rest and slide them.</p>
	<p>Tighten the shoulder rest pins (10) by hand. Make sure that the shoulder rests do not move.</p>
	<p>Thread the one of the adjustable rope (11) firstly from a pulley. Then thread it from the first bridge, the cleat, second bridge and down the hole as shown in the figure. Repeat with the second rope. To adjust a rope, lift it from cleat to the desired length, and push it back into the cleat to secure.</p>
<p><i>Insert the straps(11) or handles(12) into the metal ring at the end of the adjustable ropes.</i></p>	

### **3.4. Installation Instructions of Accessories**

#### **3.4.1. Installation Instruction of the Handles**

According to your exercise put the handles (12) in to the springs or adjustable ropes

#### **3.4.2. Installation Instruction of the Jump Board**

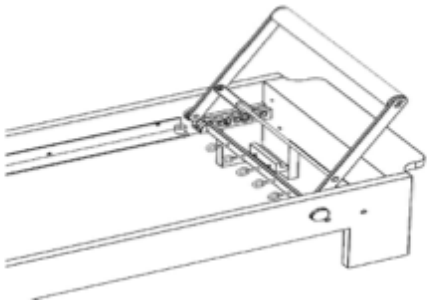
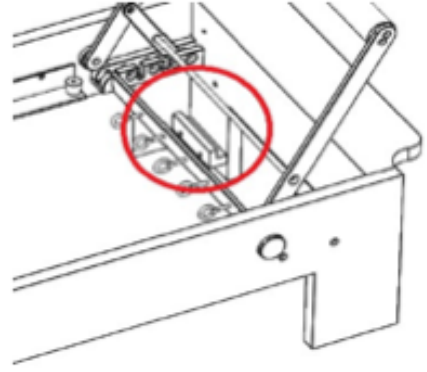
	<p>Secure the footbar to the 2nd stage as shown.</p>
	<p>Place the jump board (13) through the footbar and place it in the jump board slots. The soft face of the jump board should face the inside of the case.</p>

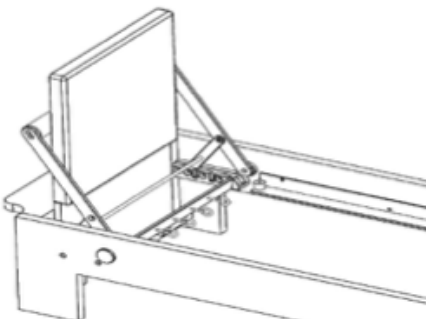
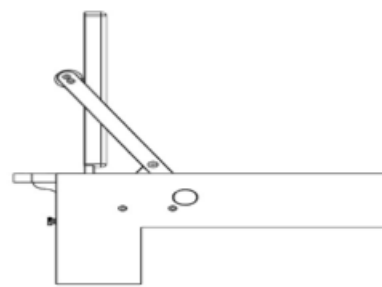
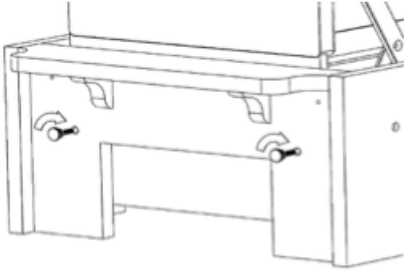
	<p>Fix the jump board as shown in figure</p>
	<p>Make sure there are no gaps between the footbar and the jump board.</p>
	<p>Tighten the jump board screws (14) as shown. Make sure that the springboard does not move.</p>

#### **4. MAINTENANCE INSTRUCTIONS**

**ATRO REFORMER** which is produced with long-lasting and enduring materials will provide more long-lasting and efficient working process with the help of maintenances that you may able to perform in a short time.

It will be more important for you to do so if you use **ATRO REFORMER** in a studio or gym center.

Do not put grease on any part of **ATRO REFORMER**.

<b>MAINTENANCE INSTRUCTION</b>	<b>DAILY</b>	<b>WEEKLY</b>	<b>MONTHLY</b>	<b>ANNUAL</b>	<b>AS NEEDED</b>
<b>GENERAL OVERVIEW</b>					<b>X</b>
<b>SPRINGS</b>			<b>X</b>		
<b>CARRIER SYSTEM</b>				<b>X</b>	
<b>SURFACE</b>	<b>X</b>				
<b>COVERINGS</b>	<b>X</b>				
<b>ROPE</b>				<b>X</b>	
<b>STRAPS</b>					<b>X</b>

**All parts of the ATRO REFORMER:** Check the whole system of the **ATRO REFORMER** is well-set daily and the screws are firm in each two months.

**Springs:** We advise you to check the all springs before use. There is always a possibility of having error and lapse even if they are tested many times before they are delivered to your end. Springs are made of galvanize, they do not become old very fast and have rust. The color on the instrument provides you to have the same performance. Clean anything compressed in between.

### **Cleaning:**

- You shall use cotton made cloth for metal parts.
- It will cause to have long-lasting period of use if you clean the coverings after each use. You shall use soap-based cleansing products. Do not use alcohol-based cleansing products.
- Clean the carrier system with the soft and dewy cloth and wipe it with dry cloth.
- You shall change the straps in case of they become non-usable or present a danger.

### **IMPORTANT WARNINGS:**

**ATRO REFORMER** is aimed to use in domestic places. Do not use the deice in outside and/or domestic places with moist and insufficient ventilation.

If you do not have the knowledge and experience, ask for help from an expert or a trainer.

Errors caused by the user are considered outside the scope of the warranty.